



PALBOARD™

Multilayered PVC Sheet

Fabrication Guide



Contents

Introduction to PALBOARD™	2
Features and Benefits	2
Milling\Routing	3
V-Groove	3
Thermal Expansion / Contraction	4
Screwing and Nailing	4
Installation	4
Tips on Sign Installations with Posts	4
Significant Items to be Considered	4
Hanging Signs	4
Adhesive Bonding of PALBOARD™	5
Heat Bending	5
Painting	6
Graphic Applications	7
Direct Digital Printing	7
Laminating	8
Chemical Resistance	10
Physical Properties	14
Flammability	14
PSDS Information (Replaces MSDS)	14



Some Foam PVC products manufactured by others may contain lead. PALBOARD™ is manufactured without lead or any other heavy metal.

Introduction to PALBOARD™

PALBOARD is an innovative multilayered sheet that offers the qualities of rigid and foamed PVC together.

Based on Palram's 50 year experience in extruding quality PVC sheets, it combines the surface quality and characteristics of rigid PVC with a reduced weight due to a recycled foamed PVC core.

PALBOARD is easy to fabricate, making it ideal for a wide variety of sign and display applications. It makes an excellent printing substrate and is suitable for digital or traditional printing. PALBOARD can be used in harsh chemical environments due to its high chemical resistance.

Main Benefits

- Hard smooth surface
- Recycled lightweight foamed PVC core
- High structural strength with a relatively low weight
- Excellent chemical and fire resistance
- Easy to fabricate and thermoform
- Good adhesion capabilities
- Good electrical and thermal insulation

Cutting

Bridge Saw

For best results use a 17.72" blade, 100 teeth. Recommended cutting speed is up to 10.668 m\min. (35 ft.\min.)

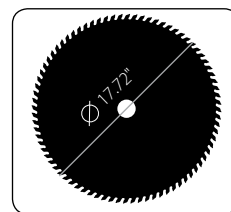

Circular Saws

PALBOARD material up to 3 mm thick can be cut with a knife or blade. For PALBOARD sheets 3 mm and thicker, carbide-tipped, High speed steel blades normally recommended for wood or plastic 10" x 72 tooth can be used.

The following settings are recommended:

- **Rake angle:** 0° - 8°
- **Clearance angle:** 10° - 15°
- **Cutting speed:** 1,220 - 2,440 meter per minute (4,000 - 8,000 feet per minute)
- **Feed rate:** 6 - 30 meter per minute (19 - 98 ft per minute)
- **Tooth pitch:** 5 - 12 mm (0.197 - 0.472 inch)

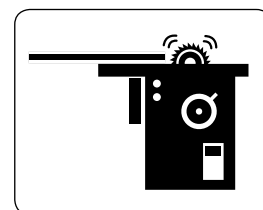

Band Saws

High speed steel blades normally recommended.

- **Teeth:** 180 tooth blade
- **Cutting speed:** 914 - 1,524 meter per minute (3,000 to 5,000 feet per minute)
- **Feed rate:** 6 - 30 meter per minute (19 - 98 ft per minute)

Jigsaw

Rough cut type blades ground for plastics can be used on PALBOARD sheets. Smooth metal-cutting blades are not recommended.

Table Top Cutters/Vertical Cutters

It is recommend using vertical cutters with Twin Wheel Head blade which are used for cutting ACP (Aluminum Composite Panel).

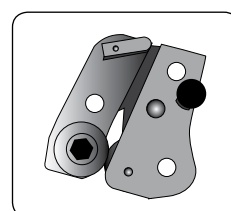

Drilling

PALBOARD can be drilled with carbide-tipped bits using twist drills recommended for metals. The following settings are recommended:

- **Point angle:** between 90° - 110°
- **Spiral angle:** 30°
- **Cutting speed:** 1,000 - 3,000 RPM (Revolutions per minute)
- **Feed rate:** 0.2 - 0.5 mm/revolution



The minimum distance from the edge should be 2 times the hole diameter. In an effort to reduce heat buildup during drilling of thicker PALBOARD sheets, it may be necessary to periodically remove the drill bit from the PALBOARD material.

Milling\Routing

PALBOARD can be milled by using standard milling machines of various types utilizing the following guidelines:

- **Relief angle:** 5° to 10°
- **Rake angle:** -10° to 0°
- **Cutting speed:** up to 18,000 RPM
- **Cutting feed:** 0.3-0.5 mm / revolution

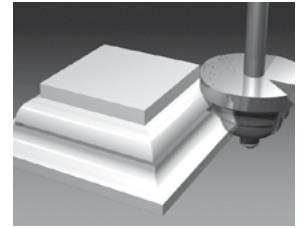

PALBOARD material can be easily routed using multi-fluted carbide tools on standard woodworking routers. Standard tools and machines can be utilized with no need to alter equipment. Adjust feed and speed rates as needed to achieve the best edge finish on the PALBOARD parts.

For Milling\Cutting\Engraving it is recommend to use a Single Flute\Tooth 'UP Cut Bit' (Left Hand Bit). The recommend cutting diameter (*d*) is 4 mm (0.1575 in); the Length of cut (*ℓ*) is 12 mm (0.472 in).

For the following Bit manufacturers the specified bit is:

- ZUND: 3910720
- ESKO: BIT-ADS06-4012-50
- VHF: ES-PS-0300-4-120-50
- CROWN-NORGE: S1-4.0/4-12-50 A
- ONSRUD: 63-750 SC 1F Upcut "O" Flute
- ONSRUD: 52-707 SC 2F Upcut "O" Flute



V-Groove

For V Groove Milling\Routing, it is recommended to use a bit specified for bending applications. Such bits offer top angles of 90°, 120° or 135°.

Application:

For bending applications use the 3, 5 & 10 mm PALBOARD sheets. The Bit with 90° produces rectangular bending with nearly no gaps. The 120° or 135° rounded tip bits produce acute angled bending of up to 90° with approx. 2 mm (0.079 inch) gap between the sides.

Practical tip:

Please note: Leave a remainder of 0.6 mm to 0.8 mm (0.024 inch to 0.032 inch) of the PALBOARD which must not be milled.

For the following Bit manufactureres the specified bit is:

- ZUND: 90° - R141 (3910799)
- ESKO: 90° - BIT-EBV06-94 | 120° - BIT-EBV06-120-2F
- VHF:
 - 45° - BIT- RB-AV-135-1800-6-59
(to remain 0.8 mm (0.032 inch) of lower layer)
 - 90° - BIT- ES-AV-090-1000-180-6-50
(to remain 0.7 mm (0.0276 inch) of lower layer)
- ONSRUD: 37-52 Carbide 2F V Bottom

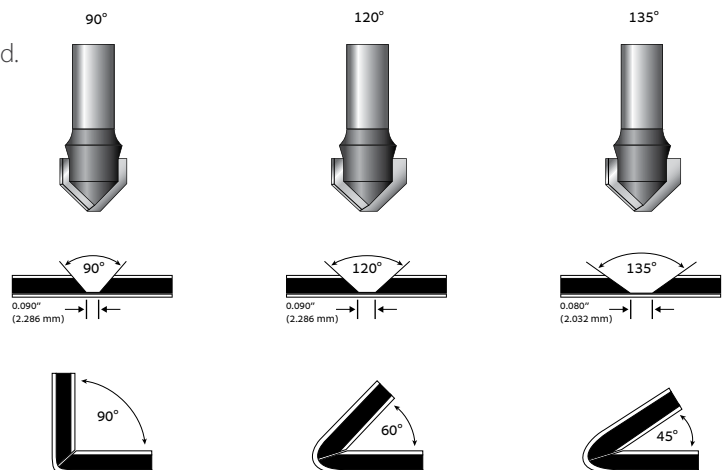

Thermal Expansion / Contraction

As with most plastics, PALBOARD Multilayered PVC Sheet will expand and contract with an increase or reduction in temperature. This material property is known as linear thermal expansion and contraction.

Since PALBOARD can be used in a wide variety of indoor and outdoor applications, linear thermal expansion and contraction may need to be considered during the fabrication and installation of the material. It is important to take in to account the temperature at which the PALBOARD material was fabricated as well as the temperature of the installation.

PALBOARD should not be used in applications or climatic conditions that exceed 60°C(150°F) (ambient or surface temperature), at which temperature the PALBOARD will soften and permanently deform. Dark colors are generally not recommended for outdoor use, as they absorb heat and can easily exceed the maximum allowable temperature of 60°C (150°F).

PALBOARD Linear Expansion / Contraction Quick Reference				
Total Temp. Change (Δ)	Expansion / Contraction of Material at Standard Lengths / Widths (in mm)			
	1220	1500	2440	3050
-7°C	0.9	1.1	1.8	2.3
4°C	1.8	2.3	3.6	4.5
15°C	2.2	3.4	5.4	6.7
27°C	3.6	4.5	7.2	9.0
38°C	4.5	5.6	9.0	11.2
49°C	5.4	6.7	10.8	13.5
66°C	6.3	7.9	12.6	15.8

Screwing and Nailing

Any type of screw or nail can be used to fasten PALBOARD material. Power nailers and screw driving equipment are suggested. Inserting the screw or nail in an elongated slot or an oversized hole is recommended so that the material can expand or contract if fluctuations in temperature occur. For best results, use oversized washers or grommets in combination with screws.

Installation

PALBOARD is manufactured as a Co-Extruded PVC product with a directional grain running the entire length of the sheet. This manufacturing process gives PALBOARD greater flexural strength in the direction of the extrusion. The grain of the PALBOARD should always be installed perpendicular to the fastening point.

Tips on Sign Installations with Posts

The following tips have been compiled to be used as a general guide for fixing PALBOARD for a minimum amount of breakage. Unusual designs falling outside the examples given may require certain modifications when considering PALBOARD.

Significant Items to be Considered

1. Bolt holes should always be larger than the bolt shaft to allow for thermal expansion and contraction, thus eliminating the possible stress at bolt fixing points. The use of washers spreads the compressive load when bolts/nuts are tightened. Be sure not to over tighten as this will weaken the connection.
2. Split timber posts are the best to use because the PALBOARD is supported evenly on both sides. If steel or aluminum poles are used, nylon bolts and washers give the best results. Be certain to use an adequate number of fasteners for these types of installation. They should be evenly spaced from the top and bottom edges.

Hanging Signs

PALBOARD may be successfully used as interior hanging signs. As PALBOARD is an Co-Extruded sheet product, thin gauges or large hanging signs may require additional support. The addition of an aluminum or thick walled plastic "C" channel across the top, bottom, or around the perimeter may be needed to alleviate any tendencies to warp. When the additions of supporting channels are not an option, the method illustrated below may also be used to help prevent bending. Holes should be located 2-1/2 times material thickness from edge.

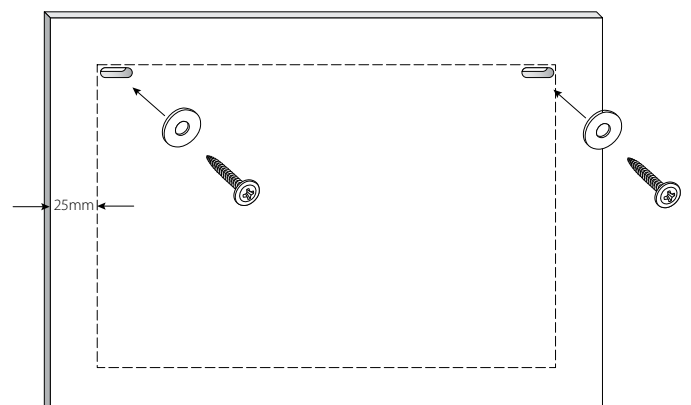

Adhesive Bonding of PALBOARD™

General Information

PALBOARD material can readily be bonded to itself or other materials. Commercially available adhesives that are suitable for bonding rigid PVC materials can be used for this purpose.

There are several considerations when choosing an adhesive:

1. The material to be bonded with PALBOARD
2. Strength required—structural vs. non-structural
3. Temperature range expected
4. Expansion/contraction
5. Ease of application methods, curing times
6. Cost effectiveness
7. Environmental and safety considerations—flammability, fumes, odors, etc.

Surface Preparation

In order to attain the optimum bond, the PALBOARD material surfaces to be bonded must be cleaned and degreased using a white cloth soaked in isopropyl alcohol to insure good adhesion.

Selection of Adhesives

The selection of the proper adhesive for a project depends on the materials to be joined, as well as the end use and other considerations mentioned previously. The following suggestions serve as general guidelines:

A. Bonding PALBOARD to PALBOARD Material

1. For edge bonding and joining parts made of PALBOARD material, use a PVC solvent such as (THF, MEK, cyclohexanone solvent systems).
2. VHB 5952 is the recommended VHB tape for PVC, Scotch Weld DP810 which is a two part low odor acrylic adhesive also bonds very well to PVC.
3. For bonding large areas: If using PVC solvent such as pipe cement, spread with notched trowel and work rapidly.

B. Bonding PALBOARD to Non-Porous Solid Material (such as PVC, other plastics or metal):

1. Contact adhesive with solvent:
 - a. Neoprene, nitrile, polyurethane or other synthetic rubber types.
 - b. Adhesive must be applied to both faces. Parallel beads of adhesive are often preferred because it allows evaporation of solvent providing faster cure.
 - c. Use a slow setting adhesive, when bonding large areas. This allows for more time to properly install the panels prior to the adhesive curing.
 - d. For bonding PALBOARD material to flexible PVC sheets, only plasticizer-resistant types of adhesives should be used.

C. Bonding PALBOARD to Porous Materials (such as paper, textiles, fabrics or wood).

1. Contact adhesive with solvent: Same systems as for non-porous materials.
 2. Construction mastic, structural silicone adhesives.
- Expected temperature ranges (expansion/contraction), substrate and size of PALBOARD material panels should be taken into consideration when deciding on a method of attachment.

Heat Bending

PALBOARD sheet material can be bent by using Calrod or other, radiant heaters, strip heaters or air-circulated ovens. Heat guns can also be used on small areas. To ensure best results, a rheostat should be used to control heating of the PALBOARD so that the surface temperature does not exceed 165°C(329°F). Heating PALBOARD material over 165°C(329°F) can cause the surface to become rough and possibly discolor.

When using a metal contact strip heater, cover the heater strip with Teflon spray to prevent marking the PALBOARD. Different sizes of rectangular heating bars can be used to produce bends of different radii. The larger the heated area of the PALBOARD, the larger the radius that can be created. PALBOARD should be heated from both sides when the sheet is thicker than 4 mm. PALBOARD requires heating at the rate of approximately 30 to 40 seconds per millimeter of thickness prior to bending.

To form tighter bends with smaller radii, use a small heated area on the upper surface (inside the bend) of the PALBOARD sheet and a larger heated area on the bottom surface (on the outside of the bend) of the sheet. A minimum radius of twice the sheet thickness is necessary to avoid breakage. When bending PALBOARD into an angle, typically the extension of the PALBOARD on either side of the angle should be at least 20 times the thickness of the PALBOARD material.

For example, 6 mm PALBOARD would require the extension on each side to be 120 mm in order to avoid warping of the material. For sides less than 20 times the material's thickness, the entire sheet must be heated. Once the PALBOARD is bent, place it in a fixture, such as a jig or clamp, to cool. Fans and/or compressed air will speed the cooling process.

Painting

The painting of PALBOARD is easily accomplished with paints known to have compatibility with rigid PVC. Selection of a paint system for each use should be guided by the following:

I. Types of paints known compatible with PALBOARD™ sheet

- A. Vinyls
- B. Acrylic Lacquers
- C. Two part polyurethanes

With PALBOARD, water-based latex systems and oil-based enamels generally do not have the good adherence properties of solvent based systems. Although, the use of primers can improve the adherence of non-solvent based systems, the adherence is usually minimal.

II. Surface Preparation

- A. The surface to be painted must remain dry, clean, and grease free.
- B. Any surface scratches on PALBOARD will have a tendency to telegraph through the paint. In order to remove small scratches or dents, rapidly fan a heat gun over the affected area. Care must be taken not to leave the hot air in one place for too long, as the surface can be deform.
- C. It is highly recommended that the surface be cleaned with a rag moistened with isopropyl alcohol prior to painting.

III. Adhesion Test - 'Cross-cut' Test

- A. The paint system chosen should always be tested for adequate adhesion. To test for adhesion, conduct the Cross Hatch Test after the paint has dried for at least 24 hours.
 1. Make eleven parallel cuts 1/16" apart with a razor blade knife. Make eleven similar cuts at 90 degrees to cross the first set.
 2. Across the scored area apply a strip of strong tape, such as #610 Scotch tape. Press firmly.
 3. Immediately remove the tape by pulling it back upon itself at 180 degrees in one rapid motion.
 4. There shall be no removal of the paint squares to obtain a good adhesion rating.

IV. Application

- A. Paints can usually be applied with a brush or roller, although conventional air spray equipment will provide a more consistent appearance.
- B. Consult paint manufacturer's literature for recommended application technique and thinning requirements.

V. Drying

PALBOARD is a thermoplastic material. It should not be dried at temperatures in excess of 150°F. For drying and cure times, consult paint manufacturer's literature.

CAUTION: Due to the wide variety of paint products on the market, and the fact that some paints have been known to embrittle or bow PALBOARD, testing is recommended for the initial use of any coating system before commercialization.

Graphic Applications

PALBOARD performs superbly in a wide range of graphic applications including those involving paints, screen printing, digital wide format printing and vinyl films. PALBOARD can be used to create weather-resistant signs, displays or Point of Purchase (POP) materials. The smooth PALBOARD surface is ideal for all types of graphics, and it does not require surface preparation or surface treatment.

Screen Printing

With PALBOARD, the process of Screen Printing is easily accomplished. The surface of PALBOARD has a closed cell semi-matte finish that makes mistakes easily wipe off with the appropriate thinner. The use of Vinyl and Vinyl/acrylic, solvent based inks are very compatible with PALBOARD.

The use of Water Based Screen Printing Inks has also had some success with PALBOARD material. Ink manufacturer directions must be followed for good adhesion. Surface preparation of PALBOARD for screen printing is similar to those of painting.

A. The surface to be screen printed area must remain dry, clean, and grease free.

B. Any surface scratches on the PALBOARD will have a tendency to show through the ink.

In order to remove small scratches or dents, rapidly fan a heat gun over the affected area. Care must be taken not to leave the hot air in one place for too long, as the surface can become deformed. It is highly recommended that the surface be cleaned with a white cloth moistened with isopropyl alcohol prior to printing.

All screen printing inks should be tested in a manner which duplicates your printing process before initiating production. It is strongly recommended to consult the appropriate ink manufacturer regarding any required ink additives such as catalyst for proper adhesion and exterior usage. Screen Printing ink should air dry, rather than be heat dried. Temperatures in excess of 150°F may cause warping or bending of PALBOARD material.

Most UV Screen Printing Inks that are compatible with rigid PVC will work on PALBOARD. The most important factor to be considered when using UV systems is the curing oven. Low wattage bulbs should be used to keep the temperature below 150°F. The use of UV curing systems, which have variable speed conveyors, are considered the best type to use with PALBOARD.

Direct Digital Printing

Wide format and flatbed printers use various ink and ink curing technologies to allow high quality printing at relatively high speeds. High quality digital printing depends on various factors:

- Printer capabilities
- Ink technology and quality
- Type of printing substrate and quality
- Machine operator

PALBOARD'S bright whiteness enables printers to print directly on it and achieve accurate, consistent color values and brightness. The PALBOARD is suitable for use with UV-LED curing and solvent-based digital inks, and for IR drying when water-based inks are used.

PALBOARD retains superb whiteness, even after intense UV curing.

Protective Film Masking

The protective polyethylene film mask helps prevent surface abrasion and stains. However, removing the protective film may cause an increase of static electric charge, which can affect ink coverage. Therefore, after peeling the film away from the sheet, the static electricity that has built up in the sheet should be discharged using an ionized gun or a suitable device provided by the printer manufacture.

Ink

PALBOARD is suitable for all types of inks: Aqueous, Solvent-Based, and UV-LED curable. In fact, PALBOARD has been tested and approved by major printer OEM's around the world, including AGFA, Efi, HP, Mutoh, Canon, and more. Consult the printer manual or contact the printer manufacturer for recommendations and compatibility information.

Drying the ink

The two main drying technologies are:

IR (Infrared) – Long exposure to high temperature in the drying tunnel may cause distortions in the sheet.

UV (Ultraviolet) – UV-LED levels must be adjusted according the printing speed and substrate. UV overexposure can cause discoloration of both the ink and substrate.

Print Head Adjustment

The distance between the print head and the substrate can have a significant affect on print quality. Manufacturer specifications, combined with an operator experience, should determine print head distance from the substrate.

The suggested starting distance should not be more than 1.5 mm from the print head to the substrate.

Laminating

PALBOARD is an ideal material for applications that require lamination. This section provides preparation information processes as well as detailed instructions for the various types of lamination that can be used with PALBOARD. Because prints are one of the most frequently laminated materials, the sections that follow will generally refer to the lamination of a print, although many other materials can be used.

Please Note! Since PALBOARD material may warp when heated above 150°F or when heated from one side only, it cannot be used in any lamination process requiring heat.

Adhesion

For best results, the PALBOARD material should be cleaned with isopropyl alcohol prior to adhesion and allowed to dry thoroughly. When laminating with pressure-sensitive adhesives, a force of 25–40 psi is required. Proper spacers are also critical. Because force must be applied equally across the material, the top roll must move evenly from left to right while maintaining even contact between top and bottom laminating rolls. To achieve even contact, “zero the nip,” then use spacer shims to preset the nip opening for a particular laminate. Use sufficient pressure to completely eliminate any air bubbles between the PALBOARD material, the adhesive and the print or other material.

The lamination will achieve maximum bonding in three hours. If the lamination has been performed properly, the finished mount can be flexed without the print becoming loose in the center. To prevent moisture from becoming trapped between layers of porous material (such as paper) and creating blisters, the level of moisture in both the material to be laminated and the atmosphere should be reduced before pressing. Some materials may require pre-drying. PALBOARD is nonporous and does not need pre-drying.

Preventing Surface flaws

Surface blemishes, such as wrinkles, can be caused by misalignment of the adhesive roll or too much pressure or rollers that are not parallel. Trapped dirt or lumps of hardened adhesive common with glossy prints may create small bumps in the finished product. In order to prevent these problems, equipment used for PALBOARD lamination must be kept clean. Use a fresh roll or sheet of transfer adhesive if bumps are caused by hardened adhesive. Dirt problems can be minimized by using an ionizing static eliminator. Using prints or other materials made with a paper 0.007" or thicker can help prevent strike through. For best results, wipe down the back of the print and the face of the PALBOARD mount with a clean, dry cloth before it passes through the roll nip. Whether the finished product is to be used indoors or outdoors, a clear, high gloss overlay will help protect against fading as well as enhance the color.

Laminating Techniques

Four techniques are recommended for laminating materials to PALBOARD, as described in the following sections. Depending upon the type of applications and the equipment available, one or more of these processes may be appropriate for a particular application. None of these processes involves the use of heat. Because PALBOARD may warp at temperatures above 150°F or when heated from one side only, it cannot be dry mounted or hot mounted.

The four recommended lamination techniques for PALBOARD are:

- Cold laminating with a press using adhesive-backed paper
- Cold laminating using a vacuum press
- Hand laminating using transfer adhesive
- Hand laminating using spray adhesive

Cold Laminating with a Press using Adhesive-backed Paper

This process is most frequently used by commercial photo labs. Either of two types of liner films, a single release liner film or a double release liner film, can be used for this process. The basic process for laminating with a press using adhesive-backed paper is described in the following section.

1. Set the roller pressure properly for the thickness of the pre-coated mounting substrate.
2. Place the mounting substrate on a flat surface and expose approximately one inch of the adhesive by peeling back the release paper. Fold back the release paper, making an even crease across the paper.
3. Carefully position the print on top of the substrate, using the folded release paper to prevent contact with the exposed adhesive. Once positioned correctly, carefully apply the print to the exposed adhesive, pressing from the center toward the edges to ensure a smooth tack.
4. Place the direction switch in the forward position and the speed control on medium.
5. Insert the materials to be processed into the laminator opening. Feed the substrate between the rollers until the pressure roller rests on the tacked portion of the material.
6. Hold the un-tacked portion of the print up and against the pressure roller. Feed the substrate through the rollers while peeling the release paper off the mounting substrate with one hand. To prevent wrinkles, the print must be held against the roller with the opposite hand while the substrate feeds through the press.
7. Remove the mounted print from the rear of the laminator and trim it to the required size.

Coating using Single Release Liner Films

1. Set the pressure properly for the thickness of the substrate(s) to be processed.
2. Load the supply roll of pressure-sensitive adhesive.
3. Pull approximately 12 inches of adhesive film forward off the roll. Rest the film, adhesive side up, on top of the pressure roller.
4. Create a leader board by cutting a piece of substrate slightly larger than the width of the adhesive film and approximately four to six inches long. Lay the leader board across the adhesive film and smoothly adhere the bottom of the leader to the adhesive.
5. Place the direction switch in the forward position and the speed control on medium.
6. Pull the leader down and push it between the rollers. Feed the leader between the rollers approximately three to four inches. Be sure that the adhesive stays firmly adhered to the leader.
7. Once this process has been completed (referred to as "stringing the web") and the adhesive is feeding without wrinkles, the laminator is ready for production.
8. To coat, feed a substrate behind the leader board and between the roller while depressing the foot switch. Feed until the substrate exits the rollers and automatically stops feeding. At this time, another substrate may be fed between the rollers for coating. This process is suitable for films with a paper release liner and leaves a 3/8" to 1/2" gap between the coated substrates to facilitate the trimming process.
9. After exiting the laminator, the coated substrates should be split apart and trimmed.

Coating using Double Release Liner Films

Coating with double release liner film, requires the use of a take-up mechanism to automatically remove and rewind one of the release liners during the coating procedure.

1. Set the pressure properly for the thickness of the substrates to be processed.
2. Load the supply roll of pressure-sensitive adhesive.
3. Adhere double-stick tape or a pressure-sensitive adhesive film, to the surface of the take-up shaft.
4. Pull approximately 18 inches of adhesive film forward off the roll and adhere one release liner side smoothly to the take-up shaft, taking care to ensure that the film is square with the supply roll and no diagonal wrinkles are apparent.
5. Separate the adhesive film from the release liner secured to the take-up shaft and pull the adhesive film and remaining release liner down so that it rests adhesive side up on top of the pressure roller.
6. Lay a leader board the same thickness as the substrates to be used across the exposed adhesive.

Chemical Resistance

The mechanism of chemical attack on thermoplastics in general, and Palram PVC sheets in particular, differs significantly from the mechanism of corrosion of metals. Corrosion of metals results in a gradual loss of surface material as a result of electrolytic action by the relevant chemicals. Chemical attack on Palram PVC sheets, where it occurs, consists generally of absorption of the chemical by the PVC sheet and its subsequent swelling. The chemical resistance behavior of Palram PVC sheets is therefore simple to determine. The chemical resistance is expressed in terms of weight change (usually an increase) and volume change.

The table that appears in the following pages lists the resistance of Palram PVC sheets to a number of commonly encountered chemicals and other corrosive media at room temperature. (Information on chemical resistance at higher temperatures will be supplied upon request.) Where the chemical resistance varies with concentration, the results of tests at different concentrations is presented. The information listed is based on long-term laboratory tests and actual service installations. For chemicals and corrosive media not listed in the list, please contact your Palram representative. He will place you in contact with the Palram Technical Support Department. It is important to note that Palram PVC sheets are generally not recommended for use with acetone, ketones, ethers, and aromatic and chlorinated hydrocarbons.

The information on chemical resistance is based on our research and experience. It serves as a basis for recommendation. Palram does not guarantee chemical resistance, unless specific tests are carried and separate documentation is supplied.

The table on the following page uses the following key:

R Resistant LR Limited Resistance (gradual attack over time may occur)

N Not Resistant (rapid attack or attack over short time period will occur)

IMPORTANT NOTE: The most up-to-date version of the information below is available on www.palram.com.

*Concentration for aqueous solution except where noted

Chemical	Concentration %*	Resistance	Chemical	Concentration %*	Resistance
Acetaldehyde	100	N	Bromobenzene		N
Acetic Acid	80	R	Butadiene		N
Acetic Acid	100	LR	Butane		N
Acetic Anhydride		N	Butyl Acetate		N
Acetone		N	Butyl Alcohol		R
Acrylonitrile		N	Butyl Stearate		R
Acetylene		R	Butyric Acid		N
Ajax		R	Calcium Chloride	Saturated	R
Allyl Alcohol		LR	Calcium Hydroxide		R
Aluminum Chloride	Saturated	R	Calcium Hypochlorite		R
Aluminum Fluoride		R	Calcium Nitrate		R
Aluminum Hydroxide		R	Calcium Sulfate		R
Aluminum Sulfate	Saturated	R	Camphor		R
Ammonia (Gas)		R	Carbon Dioxide Gas (Moist)		R
Ammonia (Liquid)		N	Carbon Disulfide		N
Ammonium Acetate		R	Carbon Monoxide		R
Ammonium Bifluoride		R	Carbon Tetrachloride		N
Ammonium Bisulfate		R	Castor Oil		R
Ammonium Chloride		R	Caustic Potash (Potassium Hydroxide)	50	R
Ammonium Fluoride	25	LR	Caustic Soda (Sodium Hydroxide)	50	R
Ammonium Hydroxide	28	R	Chlorine Dioxide	15	R
Ammonium Nitrate		R	Chlorine Gas (Dry)		N
Ammonium Sulfate	Saturated	R	Chlorine Gas (Wet)		N
Ammonium Sulfide	Saturated	R	Chlorine Water	2	R
Amyl Acetate		N	Chloroacetic Acid		R
Amyl Alcohol	Pure	LR	Chlorobenzene		N
Aniline		N	Chloroform		N
Antimony Trichloride		R	Chrome Alum	Saturated	R
Aqua Regia (3 parts HCl:1 part HNO ₃)		N	Chromic Acid	10	R
Arsenic Acid	80	R	Citric Acid	Saturated	R
Barium Chloride		R	Copper Fluoride		R
Barium Hydroxide		R	Copper Nitrate		R
Barium Sulfate		R	Copper Sulfate		R
Barium Sulfide		R	Corn Syrup		R
Beer		R	Cottonseed Oil		R
Beet (Sugar Liquor)		R	Cresol		N
Benzaldehyde		LR	Cresylic Acid	50	R
Benzene		N	Cupric Chloride	Saturated	R
Benzoic Acid		R	Cuprous Chloride	Saturated	R
Benzyl Alcohol		R	Cyclohexane		N
Bleach	12% Chlorine	R	Cyclohexanol		N
Boric Acid		R	Cyclohexanone		N
Brake Fluid		LR	Dextrose		R
Brine		R	Detergent (most)		R
Bromic Acid		R	Diesel Fuel		R
Bromine (Liquid)		N	Diethyl Ether (Ethyl Ether)		R
Bromine (Water)		LR	Dimethyl Amine		N
Bromine (Vapor)	25	R	Diethyl Phthalate		N

The table on the following page uses the following key:

R Resistant **LR** Limited Resistance (gradual attack over time may occur)

N Not Resistant (rapid attack or attack over short time period will occur)

IMPORTANT NOTE: The most up-to-date version of the information below is available on www.palram.com.

*Concentration for aqueous solution except where noted

Chemical	Concentration %*	Resistance	Chemical	Concentration %*	Resistance
Dioxane		N	Linseed Oil		R
Ethanol (Ethyl Alcohol) and Water	All	R	Lithium Bromide		R
Ethanol (Ethyl Alcohol)	Pure	R	Lubricating Oil		R
Ethyl Acetate		N	Magnesium Carbonate		R
Ethyl Chloride		N	Magnesium Chloride		R
Ethylene Chlorohydrin		N	Magnesium Hydroxide		R
Ethylene Dichloride		N	Magnesium Sulfate		R
Ethylene Glycol		R	Maleic Acid		R
Fatty Acids		R	Malic Acid		R
Ferric Acetate		R	Manganese Chloride		R
Ferric Chloride	Saturated	R	Manganese Sulfate		R
Ferric Hydroxide		R	Mercuric Chloride		R
Ferric Nitrate		R	Mercuric Nitrate		R
Ferric Sulfate		R	Mercuric Sulfate		R
Ferrous Chloride		R	Mercury		R
Ferrous Hydroxide		R	Methanol and Water	All	R
Ferrous Sulfate		R	Methanol (Methyl Alcohol)	Pure	R
Fluorine Gas		LR	Methyl Chloride		N
Fluorine Gas (wet)		R	Methyl Ethyl Ketone (MEK)		N
Fluoroboric Acid		R	Methylmethacrylate		R
Formaldehyde		LR	Methyl Sulfate		LR
Formic Acid		R	Methyl Sulfuric Acid		R
Freon 11, 12, 113, 114		LR	Methylamine		N
Fluosilicic Acid		R	Methylene Bromide		N
Fruit Juices and Pulp		R	Methylene Chloride		N
Gasoline		R	Methylene Chlorobromate		N
Glucose		R	Methylene Iodide		N
Glycerine		R	Milk		R
Heptane		R	Mineral Oil		R
Hexane		N	Motor Oil		R
Hydrazine		N	Naphtha		R
Hydrobromic Acid	20	R	Naphthalene		N
Hydrochloric Acid	35	R	Nickel Chloride		R
Hydrofluoric Acid	70	LR	Nickel Nitrate		R
Hydrogen		R	Nickel Sulfate		R
Hydrogen Peroxide	50	R	Nitric Acid	60	R
Hydrogen Sulfide		R	Nitrobenzene		N
Iodine		N	Nitroglycerine		N
Kerosene		R	Nitrous Oxide	Saturated	R
Ketones		N	Oleic Acid		R
Lactic Acid	20	R	Oxalic Acid		R
Laurel Chloride		R	Oxygen		R
Lead Acetate		R	Ozone		R
Lead Chloride		R	Palmitic Acid	40	R
Lead Nitrate		R	Paracetic Acid	70	LR
Lead Sulfate		R	Perchloric Acid		LR
Linoleic Acid		R	Phenol	85	N
Linoleic Oil		R	Phosphoric Acid		R

The table on the following page uses the following key:

R Resistant LR Limited Resistance (gradual attack over time may occur)

N Not Resistant (rapid attack or attack over short time period will occur)

IMPORTANT NOTE: The most up-to-date version of the information below is available on www.palram.com.

*Concentration for aqueous solution except where noted

Chemical	Concentration %*	Resistance	Chemical	Concentration %*	Resistance
Phosphorous (Yellow)		R	Sodium Ferricyanide		R
Phosphorous Pentoxide		R	Sodium Ferrocyanide		R
Phosphorous Trichloride		N	Sodium Fluoride		R
Photographic Chemicals		R	Sodium Hydroxide	50%	R
Picric Acid		N	Sodium Hypochlorite	16% Chlorine	R
Plating Solutions		R	Sodium Nitrate		R
Potassium Bichromate		R	Sodium Nitrite		R
Potassium Bromate		R	Sodium Perchlorate		R
Potassium Bromide	Saturated	R	Sodium Peroxide		R
Potassium Chloride		R	Sodium Sulfate		R
Potassium Chlorate		R	Sodium Sulfide		R
Potassium Chromate		R	Sodium Sulfite		R
Potassium Cyanide		R	Sodium Thiosulfate		R
Potassium Dichromate		R	Stannic Chloride		R
Potassium Ferricyanide		R	Stannous Chloride		R
Potassium Fluoride		R	Stearic Acid		R
Potassium Hydroxide	50	R	Succinic Acid		R
Potassium Nitrate		R	Sugar	Saturated	R
Potassium Perborate		R	Sulfur Dioxide (Dry Gas)		R
Potassium Perchlorate		R	Sulfuric Acid		R (LR)
Potassium Permanganate	10	R	Sulfurous Acid	<80 (>80)	R
Potassium Persulfate		R	Tannic Acid		R
Potassium Sulfate		R	Tanning Liquors		R
Propane		R	Tartaric Acid		R
Propyl Alcohol (1Propanol)	100	R	Tetraethyl Lead		R
Propylene Dichloride		N	Tetrahydrofuran		N
Propylene Oxide		N	Tetrasodium Pyrophosphate		R
Pyridene		N	Thionyl Chloride		N
Pyrogallic Acid		R	Titanium Tetrachloride		R
Salad Oil		R	Toluene		N
Salicylic Acid		R	Trichloroacetic Acid		R
Selenic Acid		R	Trichloroethylene		N
Silicic Acid		R	Triethanolamine		R
Silver Cyanide		R	Triethylamine		N
Silver Nitrate		R	Trimethylamine		LR
Silver Sulfate		R	Trisodium Phosphate		R
Sodium Acetate		R	Tuepentine		LR
Sodium Benzoate		R	Urea		R
Sodium Bicarbonate		R	Vasilene		N
Sodium Bichromate		R	Vegetable Oils		R
Sodium Bisulfate		R	Vinegar		R
Sodium Bisulfite		R	Vinyl Acetate		N
Sodium Carbonate		R	Water (Demineralized or Sea)		R
Sodium Chlorate		R	Wine or Whiskey		R
Sodium Chloride		R	Xylene		N
Sodium Chlorite		N	Zinc Chloride		R
Sodium Cyanide		R	Zinc Nitrate		R
Sodium Dichromate		R	Zinc Sulfate		R

Recommended Uses and Restrictions

Please consult the relevant product and/or application information for this product within this guide, or in other related sales literature.

Further Information

Additional information on this product may be obtained by calling your Palram Sales or Customer Service Contact.

Physical Properties

Property	Standard	Conditions	Units	Value
Physical				
Density	ASTM D-792		g/cm ³	0.58 - 0.62
Water absorption	ASTM D-570	24 hr @ 23°C	%	3mm - 0.5 5mm - 0.8
Mechanical – Machine direction				
Flexural modulus	ASTM D-790		MPa	1600
Shore hardness	ASTM D-2240		Shore D	50
Thermal				
Service temperature range			°C	-10 to 55
Heat deflection temperature	ASTM D-648	Load: 1.82 MPa	°C	62
Coefficient of linear thermal expansion	ASTM D-696		10 ⁻⁵ /°C	6.7
Electrical				
Surface resistance	ASTM D-257		Ohm	4.1x10 ¹⁴

Please consult the web site for specific product specifications.

Flammability

PALBOARD is self-extinguishing and complies with the most demanding international fire resistance standards in the field of plastics, as indicated in the detailed table herein. The classification is subject to product type, thickness and color.

Standard	Thickness	Classification*
EN13501	3mm	B, s2, d0
	3-10mm	B, s3, d0
UL 94	3-10mm	V-0

* For more detailed information please contact your Palram distributor.

PSDS Sheet

Download a detailed copy of the PSDS (Product Safety Data Sheet, used in place of MSDS Sheet) for PALBOARD [Here](#).

Palram H.Q.

Tel: +972 4 8459900
Fax: +972 4 8444012
palram@palram.com
www.palram.com

Palram Europe Ltd.

Tel: +44 1302 380777
Fax: +44 1302 380788
sales.europe@palram.com
www.palram.com

Palram Americas

Tel: 610 2859918
Fax: 610 2859928
palramamericas@palram.com
www.palramamericas.com

**Build On.**

85585 - 04.2019

In as much as Palram Industries has no control over the use to which others may put the material, it does not guarantee that the same results as those described herein will be obtained. Each user of the material should make his own tests to determine the material's suitability for his own particular use. Statements concerning possible or suggested uses of the materials described herein are not to be construed as constituting a license under any Palram Industries patent covering such use or as recommendations for use of such materials in the infringement of any patent. Palram Industries or its distributors cannot be held responsible for any losses incurred through incorrect installation of the material. In accordance with our company policy of continual product development you are advised to check with your local Palram Industries supplier to ensure that you have obtained the most up to date information.

©1997 Palram industries Ltd. | PALBOARD is a registered trademark of Palram Industries Ltd.

